

HOSE COILERS

Saving firefighters backs since 1996

MC40 & MC65

- Designed to make easy work out of coiling 1" to 3" hose under any condition
- Folds up for small storage and easy transportation
- Capable of Dutch rolls
- Mounting bracket (MB) included
- Trailer Hitch and Wildland Mounting Brackets available for more flexibility in where hose can be coiled, see below



MC80

- Designed to make easy work out of coiling 4" to 7" hose
- Attaches to the Hitch Receiver of a pickup or the Tailboard of a truck
- Comes with both a Tailboard (TB80) and a Trailer Hitch (TH80) Mount
- Constructed of heavy gauge steel, for superb durability



MC40

- Rolls 1"- 1 1/2" hose
 - MB mount included
- Wt: 6.5 lbs.

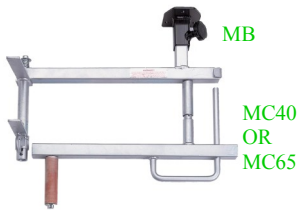

MC80

- Rolls 4" to 7" hose
- Comes with both a TB80 and a TH80 mount included



Wt: 10 lbs.

MC65

- Rolls 1 1/2" to 3" hose
- MB mount included

MB

- Additional Square Mount for the MC40 or MC65 Coilers. The Square Mount can be bolted to any Vertical surface

Wt: 1 lb.



THMB

- The THMB (Trailer Hitch Mounting Bracket) makes for quick field setup, use, and breakdown of the MC40 or MC65 Hose Coilers. It slides into any class 4 (2") hitch receiver tube

Wt: 5 lbs.



WLMB

- The WLMB (Wild Land Mounting Bracket) is great for remote use where finding a place to mount the MC40 or MC65 can be tricky. Simply drive the mount into the ground roll up the hose

Wt: 6 lb.

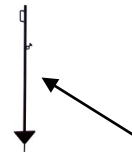

TH80

- Extra trailer hitch mount for the MC80 Hose Coiler

Wt: 1 lb.



TB80

- Extra mount for the MC80 bolts to the Tailboard so hose can be directly loaded into the hose bed of the engine. The Tailboard does not just have to mount to the tailboard. It can be bolted to any sturdy horizontal surface

Wt: 1.5 lbs.



C & S Supply, Inc.

6342 East County Road 18 • Johnstown, Colorado 80534
Ph: 888-663-4966 • Fax: 970-663-3878 • www.CSSupplyInc.com



MOUNTING & OPERATING INSTRUCTIONS



Securely bolt mount to side or back of truck so square is horizontal.

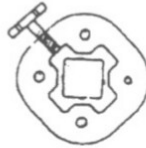

To remove handle from frame slide handle rearward away from guide end, lift handle slightly away from frame and forward until handle is free from frame.

Place frame in mount on truck so frame is horizontal and guide is in the direction you want to roll hose from.

Pull hose guide away from frame and turn one quarter turn so guide is in the vertical position and locked in place with guide bars facing up.

Lay hose end through guide and over roller. Adjust guide to same width as hose by pulling slide pin ring up and slide in direction to fit hose.

Place handle roller over roller pin on frame. Turn handle so the pin turns hose end around roller pin. For a Dutch Roll place center of hose around pin and turn handle.

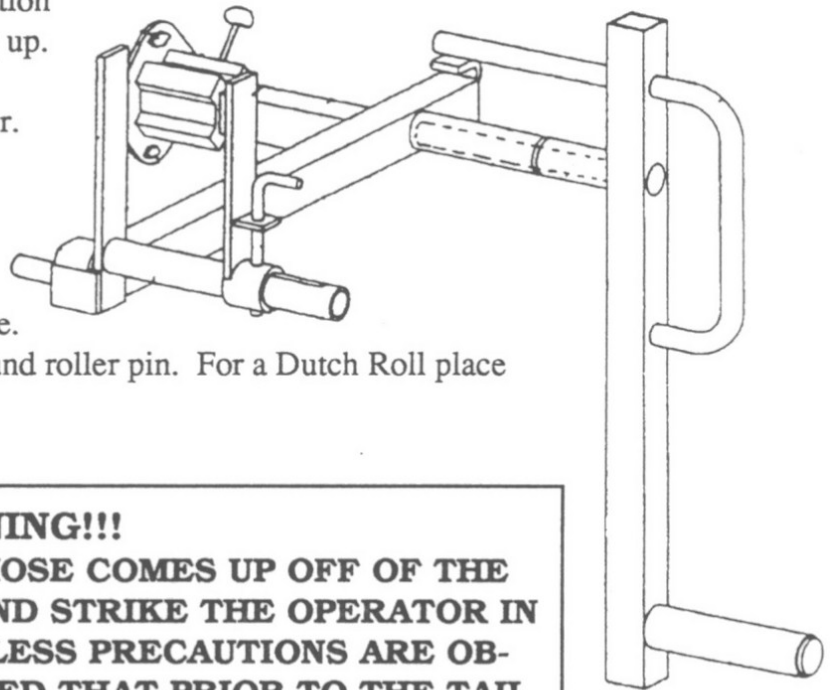
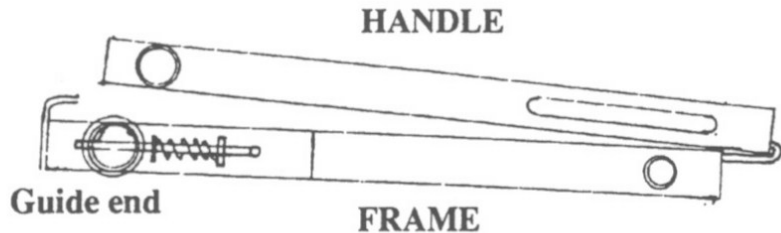

WARRANTY

Lifetime warranty covers defects in material and workmanship. Ship postage prepaid to:

McIver Enterprises
2441 East A Street
Torrington, WY 82240

WARNING!!!

AS THE TAIL END OF THE HOSE COMES UP OFF OF THE GROUND IT MAY SWING UP AND STRIKE THE OPERATOR IN A DANGEROUS MANNER UNLESS PRECAUTIONS ARE OBSERVED. IT IS RECOMMENDED THAT PRIOR TO THE TAIL END LEAVING THE GROUND THE OPERATOR COME TO A COMPLETE STOP, AND SECURE THE END WITH THE FREE HAND WHILE COMPLETING THE ROLL SLOWLY AND WITH CAUTION!

When rolled, remove hose and handle at the same time, lay hose flat and remove handle.